

Electric Driven Workholding Pumps *Application & Selection*

Shown: ZW5111SWE100



Swing cylinders
Work supports

Linear cylinders

Power sources

► Enerpac's workholding pump unit features an innovative range of zero leakage, poppet design, directional valves. With the modular valve design, various independent single-acting or double-acting circuits can be realized.

Application

These advanced workholding pumps, operating at maximum 350 bar hydraulic pressure, are highly suitable for production tooling applications – offering the optimum in terms of compact size for required oil flow and pressure rating and customization to your specific needs.

Enerpac electric pump used in conjunction with swing cylinders, work supports, directional valves, control valves and sequence valves can provide a complete clamping solution. The pressure switch allows the unit to be fully automated.

Customize to your needs

- Various models including electric controls and isolating valves
- Stackable to 8 VP-series valve stations high
- Customer adjustable relief valve
- Glycerine dampened pressure gauge G-2517L on pumps with VP-series valves
- 230/400 Volt - 50Hz - 1,1 kW Motor

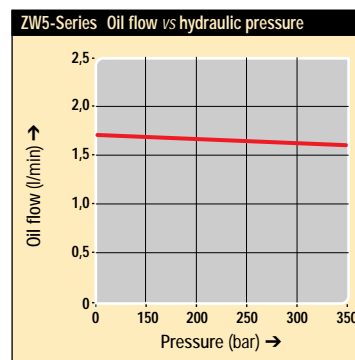

Product selection

Oil Flow rate	Pressure Range	Voltage and current 50Hz V @ A	Usable oil capacity ²⁾ litres	Valve models included	Model number	kg
▼ With manifold for VP-series modular valves, no electric controls						
1,64	100-350	230 @ 3,3	10,0	–	ZW5VPSEE100	65
1,64	100-350	400 @ 1,9	10,0	–	ZW5VPSWE100	65
▼ With manifold for CETOP 03 valves, no electric controls						
1,64	100-350	230 @ 3,3	10,0	–	ZW5C03SEE100	65
1,64	100-350	400 @ 1,9	10,0	–	ZW5C03SWE100	65
▼ For 2x Single-Acting circuits						
1,64	100-350	230 @ 3,3	10,0	1x VP-41	ZW5141SEE100	77
1,64	100-350	400 @ 1,9	10,0	1x VP-41	ZW5141SWE100	77
▼ For 1x Double-Acting circuits + Isolating Valve¹⁾ for A-port						
1,64	100-350	230 @ 3,3	10,0	1x VP-11	ZW5111SEE100	77
1,64	100-350	400 @ 1,9	10,0	1x VP-11	ZW5111SWE100	77
▼ For 2x Double-Acting circuits + Isolating Valves¹⁾ for all A-ports						
1,64	100-350	230 @ 3,3	10,0	2x VP-11	ZW5211SEE100	80
1,64	100-350	400 @ 1,9	10,0	2x VP-11	ZW5211SWE100	80

¹⁾ Isolating Valve is Pressure Switch PSCK-8.

²⁾ ZW5-series pumps comes standard with 10 litres reservoir. (4, 8, 20 or 40 litres reservoir is optional).



ZW5-series Shown: ZW5211SEE100 with standard 10 litres reservoir

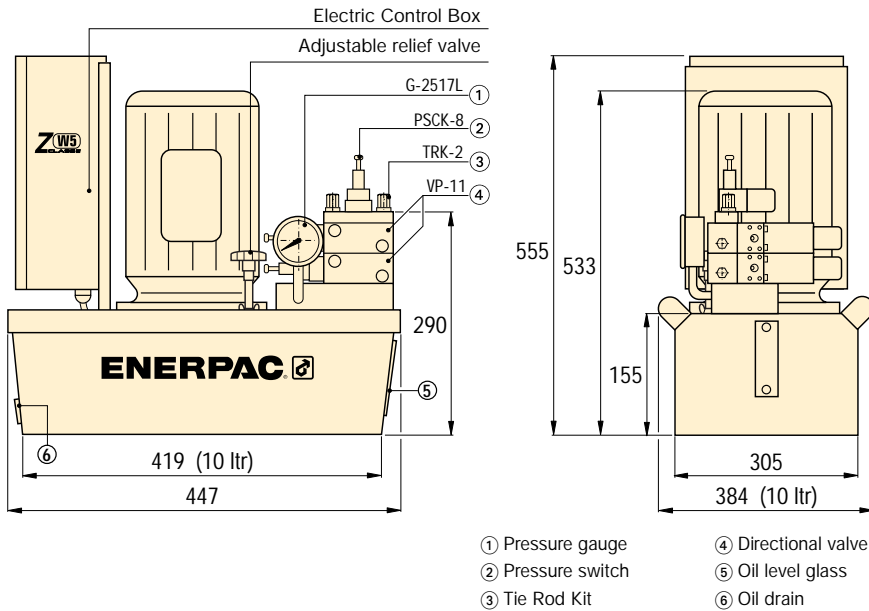

Product specifications

Pump series	Voltage	Phase	Continuous operation at 350 bar	Motor capacity	Motor speed	Motor protection class	Sound Level
	Volt			kW	RPM		dBA
ZW5....	230	1	50%	1,1	1390	IP54	75
ZW5.....	400	3	50%	1,1	1390	IP54	75

Valve options

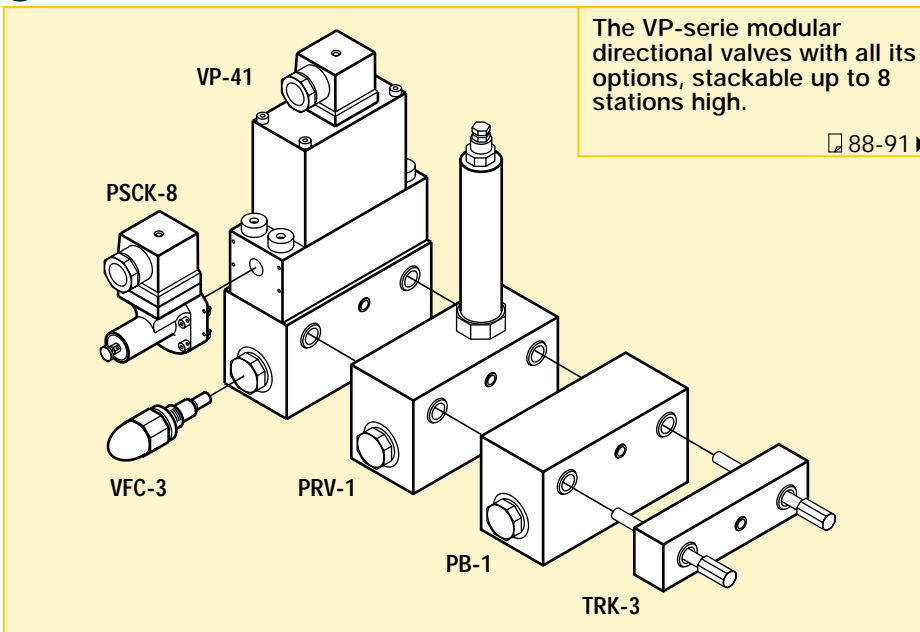

Flow: 1,64 l/min

Pressure: 100-350 bar

Motor: 1,1 kW

Reservoir: 4 -40 litres

- Ⓔ Bombas eléctricas
- Ⓕ Centrale hydraulique
- Ⓖ Modulare Spannumpme

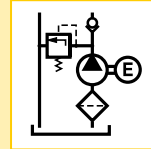

Options

VP-series, modular valves

① 88 ▶



VFC-3 Inline Flow control valve

① 89 ▶



Pressure switches

① 89 ▶



Hoses and couplers

① 108 ▶



High pressure filters

① 109 ▶



Fittings

① 110 ▶



! Important

Oil should be replaced every 500 working hours or 4 times a year whichever comes first to ensure long life.

Output flow rate should be matched to hydraulic components used in the system.

Shown: ZW5111SWE100



▶ ZW5 series

These advanced workholding pumps, operating at maximum 350 bar hydraulic pressure, are highly suitable for production tooling applications – offering the optimum in terms of compact size for required oil flow and pressure rating and customization to your specific needs.

Application

Enerpac electric pump used in conjunction with swing cylinders, work supports, directional valves, control valves and sequence valves can provide a complete clamping solution. The pressure switch allows the unit to be fully automated.

- *Enerpac VP-series valves stackbuilt on ZW5211SWE100. The pressure switch PSCK-8 is mounted directly onto the endplate of Tie Rod Kit TRK-2.*



ZW5VPSEE100 with manifold for VP-series or CETOP 03 valves, without electric controls and gauge

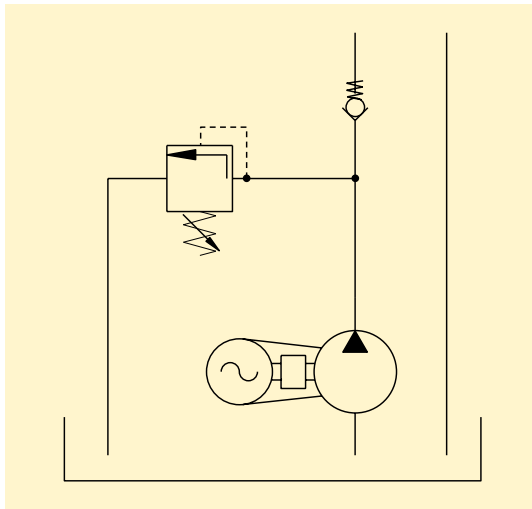

Basic pumps

Customize to your needs with the Enerpac VP-series valves and options or choose your own CETOP 03 valve.

ZW5111SEE100 For 1x Double-Acting circuit and Isolating Valve for A-port

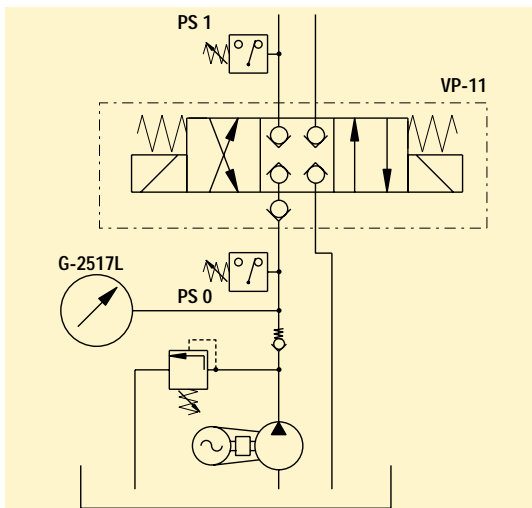

Isolating valves

For applications where clamping pressure has to be maintained, isolating valves are an economic and safe solution.

The pressure switch (PS 1) switches in the hydraulic line to the cylinder actuates the valve with a closed center position and isolates the circuit when the preset pressure has been reached. In case of pressure drop the switch opens the valve to compensate.

For some particular applications, i.e. when a workpiece has to be positioned and clamped with different forces, you can set different isolating valve pressures for the independent circuits.

ZW5141SEE100 For 2x Single-Acting circuits

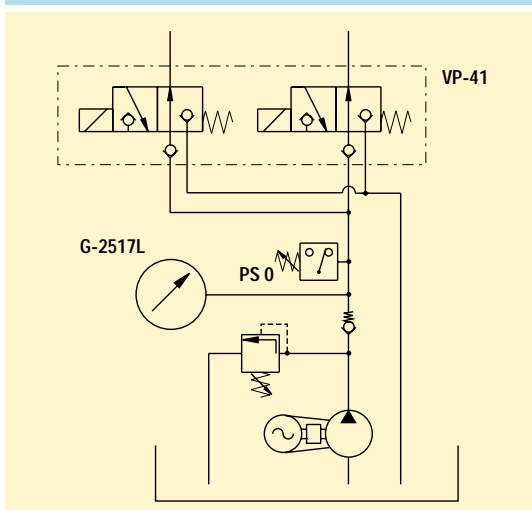

Pressure switch (PS 0) switches the motor off at maximum pressure; in case of pressure drop due to activating circuits, the motor restarts.

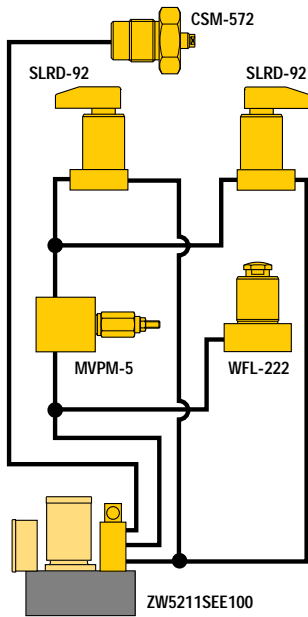

ZW5211SEE100 for 2x Double-Acting circuit and Isolating Valve for all A-ports

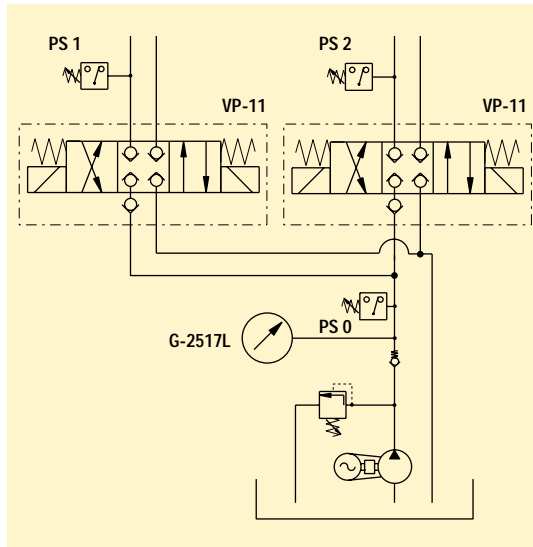

Flow:	1,64 l/min
Pressure:	100-350 bar
Motor:	1,1 kW
Reservoir:	4-40 litres

- (E) Bombas eléctricas
- (F) Centrale hydraulique
- (D) Modulare Spannpumpe

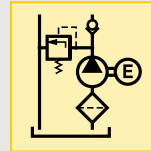

Application example

Building the right workholding system for a specific production tooling requirement is best achieved by observing the Basic System Set-up in our "Yellow Pages" (113).

Electric Scheme

Shown the electric scheme of the ZW5211SWE100 (400 volt) for two double-acting circuits and isolating valves (pressure switches) in both A-lines.

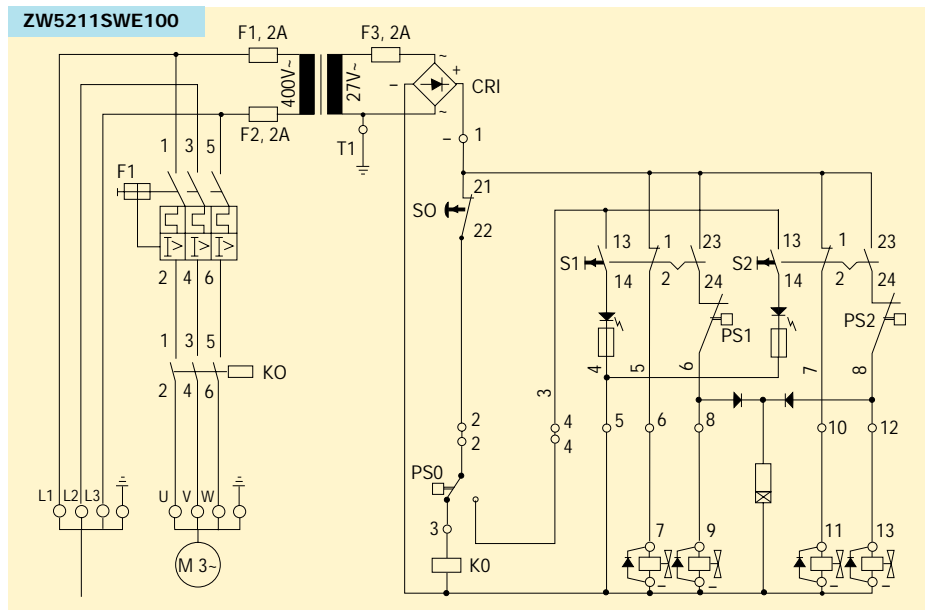

Options

Sequence valves [192](#)

Flow control valves [196](#)

Hoses and couplers [108](#)

High pressure filters [109](#)

Hydraulic oil [109](#)

Fittings [110](#)

VP-series Valve options [88-91](#)

