

Force:	6,1 - 19,5 kN
Stroke:	6,4 - 10,9 mm
Pressure:	80 - 170 bar

- (E) Cilindros giratorios
- (F) Verins de bridage pivotants
- (D) Schwenkspannzylinder

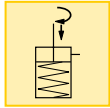

Options

Fittings



110 ▶

Hoses and couplers



108 ▶

Flow control valves



96 ▶

Gauges



106 ▶

Adjustable clamping stroke

...turns clockwise or counter clockwise

- Adjustable bolt in clamp arm for clamping stroke adjustment
- Low profile, ideal for limited space applications
- Quick swing action allows clamp arm to swing free of cutter and reclamp after it has passed
- 94-100° clamp arm swing arc

ASC-30, -100

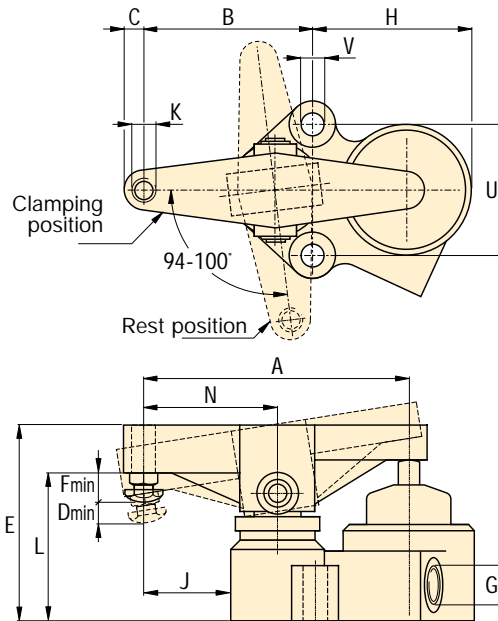

Shown: ASC-30



ASC series

Clamping arm rotates 97° clockwise or counter clockwise (requires easily changed rotation spring) to position itself over the workpiece. Then, a vertical plunger exerts an upward thrust on the back end of the swing arm providing a powerful downward pressure to clamp the workpiece.

Selection chart

Cylinder capacity	Stroke	Model number	Operating pressure	Cylinder effective area	Oil Capacity	Max. oil flow	
kN	mm		bar	cm ²	cm ³	l/min	kg
6,1	6,4	ASC-30	80-170	3,5	4,9	1,9	2,7
19,5	10,9	ASC-100	80-170	11,4	20,0	1,9	8,2

Product dimensions in mm []

Model number	A	B	C	D	E	F	G	H	J	K	L	N	U	V
	NPT						UN						∅	
ASC-30	127,0	85,9	12,7	6,4	88,9	19,1	.125-27	69,9	41,4	.500-13	69,9	63,5	63,5	10,4
ASC-100	177,8	114,3	13,5	10,9	133,4	18,5	.125-27	108	57,2	.500-13	101,6	88,9	88,9	16,0

View of a machining fixture with ASC-30 clamping cylinders.

